

PROFIFLUX IFS 5000 Electromagnetic Flowmeter

Aluminium oxide liner for demanding applications

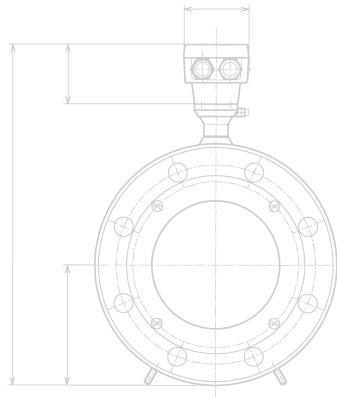

- Aluminium oxide (Al_2O_3) measuring tube, dimensionally stable, long-time stability
- Flow profile-optimizing cross-section
- Exact measurement, even under unfavourable installation conditions



HAMALL PROCESS INSTRUMENTS, DEVONPARK MILLS,
ALEXANDRA STREET, TILlicOUNTRY, CLACKMANNANSHIRE,
SCOTLAND, UK. FK13 6HP
TEL NO : 44 (0)1259 753753 FAX NO : 44 (0)1259 752770

Variable area flowmeters

Vortex flowmeters

Flow controllers

Electromagnetic flowmeters

Ultrasonic flowmeters

Mass flowmeters

Level measuring instruments

Communications engineering

Engineering systems & solutions

PROFIFLUX IFS 5000

Electromagnetic Flowmeter

Aluminium oxide liner for demanding applications

PROFIFLUX flowmeters measure the volumetric flowrate of electrically conductive liquids, acids, alkaline solutions, pastes and slurries, also with very high solids contents.

Fields of application

- All fields in which high measuring stability is called for under tough operating conditions
- Abrasion resistance: extremely high
- Chemical resistance: alkaline solutions (e.g. NaOH) up to 50% at 50°C/122°F
acids (e.g. HNO₃) up to 99% at 90°C/194°F
(HF=hydrofluoric acid, all concentrations at 50°C/122°F)

Calibrated on **EN 45 001** certified calibration rigs, accuracy of calibration better than 99.97% of the measured value.



Highlights

Dimensionally stable measuring tube, extremely good thermal and long-time stability, no flow, no creep and no abrasion, as is usually the case with plastic liners

Can be used with all KROHNE signal converters of integral or remote design

For use in hazardous locations

IP 67, equivalent to NEMA 6, type of protection, standard

Tough flow-profile optimizing Aluminium oxide (Al₂O₃) measuring tube

Fused-in-place platinum or Cermet electrodes, absolutely tight

Stainless steel housing

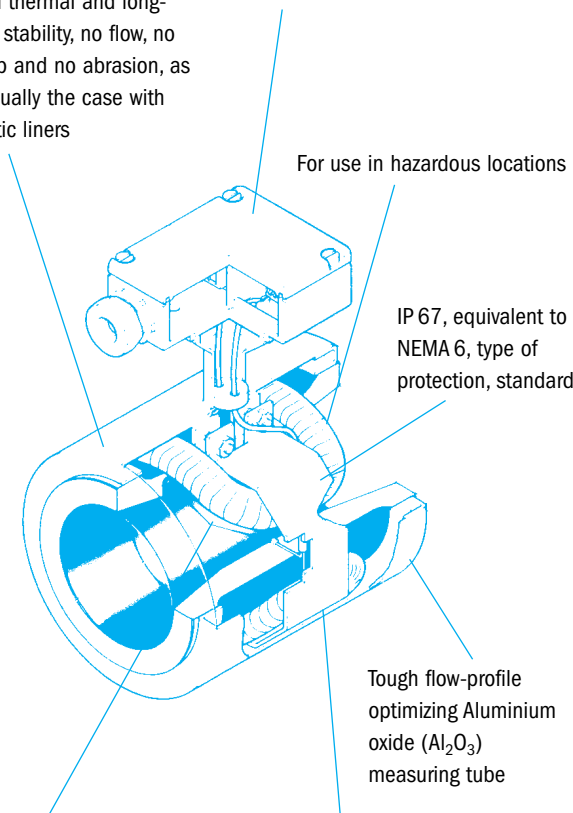

Flow profile influence (± SE)

as % of measured value

Example for DN 80 (3") with quarter bend, straight inlet run

5 x DN (= 400 mm) from quarter bend to electrode plane

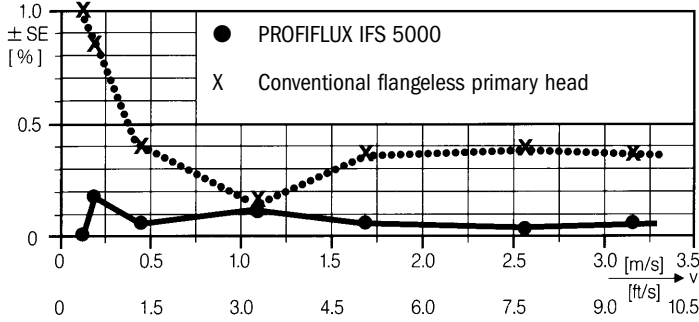

$$\text{Pressure drop: } \Delta P = \frac{\rho \times v^2}{k} \quad (\text{in mbar})$$

ρ = product density in kg/m³
 v = flow velocity in m/s
 k = 250 for DN 2.5 - 10, 1/10" - 3/8"
 k = 800 for DN 15 - 100, 1/2" - 4"

$$\text{Pressure drop: } \Delta P = \frac{\rho \times v^2}{k} \quad (\text{in psig})$$

ρ = specific gravity (e.g. water = 1)
 v = flow velocity in ft/s
 k = 200 with DN 2.5 - 10, 1/10" - 3/8"
 k = 550 with DN 15 - 100, 1/2" - 4"

Design

The self-supporting measuring tube of fused aluminium oxide is press-fitted into the stainless steel housing. The electrodes are fused into the measuring tube.

Flangeless 'sandwich' design, easy and quick to install

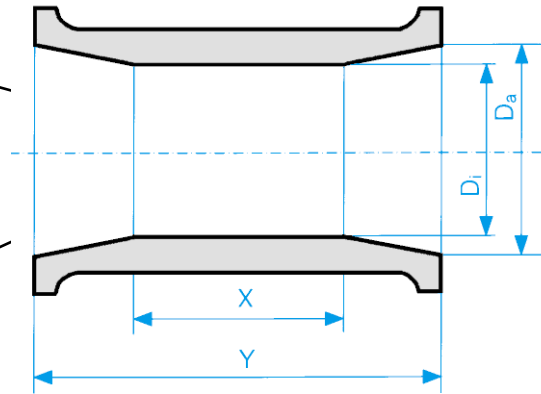

Meter sizes DN 2.5-100 and 1/10"-4", measurements down to well below 1 ampoule per second

Meter size	Dimensions in mm (inches)					
	mm	inches	D _a	D _i	X	Y
DN 2.5	2.5	1/10	6 (0.24)	2 (0.08)	20 (0.79)	50 (1.97)
DN 4	4	1/8	7 (0.28)	3 (0.13)	20 (0.79)	50 (1.97)
DN 6	6	1/4	9 (0.35)	5 (0.19)	20 (0.79)	50 (1.97)
DN 10	10	3/8	12 (0.47)	7 (0.28)	20 (0.79)	50 (1.97)
DN 15	15	1/2	14 (0.56)	12 (0.47)	20 (0.79)	50 (1.97)
DN 25	25	1	24 (0.95)	20 (0.79)	26 (1.02)	55 (2.17)
DN 40	40	1 1/2	37 (1.46)	30 (1.18)	36 (1.42)	80 (3.15)
DN 50	50	2	49 (1.92)	40 (1.57)	51 (2.01)	100 (3.94)
DN 80	80	3	78 (3.06)	60 (2.36)	70 (2.76)	150 (5.91)
DN 100	100	4	98 (3.84)	80 (3.15)	103 (4.06)	200 (7.87)

Hazardous-duty (Ex) versions

European Standard

The **IFS 5000-EEx primary heads** are approved in conformity with European Standard: EEx em ib IIC T3-T6, KEMA No. 91.C.9694X.

The following certified signal converters with integrated buffer stage are available for the remote primary heads:

IFC 090 F-Ex signal converters

in rotatable field housing for use in hazardous areas, EEx d or de [ib] II C T6.

IFC 110 F-Ex signal converters

(field housing) for use outside hazardous areas, [EEx ib] II C.

Additional information on the signal converters is provided in the relevant Data Sheets.

The **IFM 5080 K-EEx integral flowmeters** are approved in conformity with European Standard: EEx dme ib IIC T3-T6, KEMA No. 92.C.7162X.

FM Approvals

The **IFS 5000 F** primary heads are FM approved:

Div 2: NI / I / 2 / ABCD
S / II / 2 / FG
S / III / 2
J.I. No. 4X7A4.AX

For Division 1 the X 1000 F primary heads are approved:

Div 1: S / I, II, III / 1 / BCDEG
J.I.No.1K0AZ

FM approvals for **IFC 110** and **IFC 090** signal converters are pending.

The **IFM 5080 K** integral flowmeters are FM approved:

Div 2: NI / I / 2 / ABCD
S / II / 2 / FG
S / III / 2
J.I. No. 4X7A4.AX

Additional information on the signal converters is provided in the relevant Data Sheets.

Technical data

Responsibility as to suitability and intended use of our instruments rests solely with the purchaser.

Available versions

- X = standard
- O = option
- = not included in supply

	Flangeless design	With grounding rings and gaskets between primary head and grounding rings	Gaskets between primary head or grounding rings and pipe flanges	Centering rings	Centering sleeves	Stud bolts	Hazardous-duty version to European standard	FM approval	Pipe flanges (not included in supply) to DIN 2501 (= BS 4504) and ANSI B 16.5
Meter size to DIN 2501									
DN 2.5, 4, 6, 10	X	X	-	X	-	X	0	-	DN 10, 15 / PN 10
DN 15	X	X	-	X	-	X	0	-	DN 15 / PN 40
DN 25	X	0	X	X	-	X	0	-	DN 25 / PN 40
DN 40	X	0	X	-	X	X	0	-	DN 40 / PN 40
DN 50	X	0	X	-	X	X	0	-	DN 50 / PN 40
DN 80	X	0	X	-	X	X	0	-	DN 80 / PN 40
DN 100	X	0	X	-	X	X	0	-	DN 100 / PN 16 (option PN 25)
Meter size to ANSI B 16.5									
1/10", 1/8", 1/4", 3/8", 1/2"	X	X	-	X	-	X	0	0	1/2", 150 lb, RF
1"	X	0	X	X	-	X	0	0	1", 150 lb, RF
1 1/2"	X	0	X	-	X	X	0	0	1 1/2", 150 lb, RF
2"	X	0	X	-	X	X	0	0	2", 150 lb, RF
3"	X	0	X	-	X	X	0	0	3", 150 lb, RF
4"	X	0	X	-	X	X	0	0	4", 150 lb, RF

} option 300 lb, RF

Electrical conductivity		DN 2.5, 1/10" } ≥ 10 μS/cm DN 4 - 100, 1/8" - 4" } ≥ 05 μS/cm } ≥ 20 μS/cm for demineralized cold water	
Temperatures		Ambient temperature	Process temperature
Integral systems	Standard	-25 to +60°C (-13 to +140°F) -25 to +40°C (-13 to +104°F)	-60 to +060°C (-76 to +140°F) -60 to +140°C (-76 to +284°F)
	EEx version	-25 to +60°C (-13 to +140°F) -25 to +40°C (-13 to +104°F)	-20 to + 60°C (- 4 to +140°F) -20 to +140°C (- 4 to +284°F)
IFS 5000 F (remote):	Standard	-25 to +60°C (-13 to +140°F)	-60 to +180°C (-76 to +356°F)
	EEx version	-25 to +60°C (-13 to +140°F) -25 to +40°C (-13 to +104°F)	-20 to + 60°C (- 4 to +140°F) -20 to +150°C (- 4 to +302°F)
Temperature change		DN 2.5-15/ 1/10"-1/2"	DN 25-100/1"- 4"
Temperature rising	in 10 minutes:	Δ T = 150°C or 302°F	Δ T = 150°C or 302°F
	for sudden change:	Δ T = 120°C or 248°F	Δ T = 120°C or 248°F
Temperature falling	in 10 minutes:	Δ T = 120°C or 248°F	Δ T = 100°C or 212°F
	for sudden change:	Δ T = 90°C or 194°F	Δ T = 80°C or 176°F
Max. operating pressure (at product temperature ≤ 180°C/≤ 356°F)			
DN 2.5 - 80		40 bar or 580 psig	
DN 100		16 bar or 230 psig (option 25 bar/360 psig)	
1/10" - 4"		16 bar or 230 psig, for 150 lb pipe flanges	
1/10" - 3"		40 bar or 580 psig, for 300 lb pipe flanges (option)	
4"		25 bar or 360 psig, for 300 lb pipe flanges (option)	
Vacuum load		0 mbar abs. or 0 psia	
Insulation class of field coils		H	
Electrode design		fused-fitted electrodes	
Power supply for field coils		max. 60 V from signal converter	
Protection category (IEC 529 / EN 60 529)		IP 67, equivalent to NEMA 6	
Materials			
<u>Measuring tube</u>		Fused aluminium oxide, 99.7% Al ₂ O ₃	
<u>Electrodes</u>	DN 2.5 - 15, 1/10" - 1/2"	CERMET	
	DN 25 - 100, 1" - 4"	Platinum	
<u>Housing</u>			
DN 2.5 - 15, 1/10" - 1/2"		stainless steel 1.4462/Duplex	
DN 25 - 100, 1" - 4"		stainless steel 1.4301 or SS 304 - AISI	
<u>Terminal box</u>		Die-cast aluminium, with polyurethane finish	
<u>Grounding rings</u>		stainless steel 1.4571 or SS 316 Ti - AISI, others on request	
<u>Gaskets between primary head and grounding rings</u>			
DN 2.5 - 15 / 1/10" - 1/2"		Viton O-rings, optionally EPDM or Kalrez	
DN 25 - 100 / 1" - 4"		Gylon 3500 (beige) gaskets (application range similar to that of PTFE), optionally Chemotherm (graphite) gaskets	
<u>Gaskets between primary head or grounding rings and pipe flanges (DN 25 - 100, 1" - 4")</u>			
		Gylon 3500 (beige) gaskets (application range similar to that of PTFE), optionally Chemotherm (graphite) gaskets	
<u>Centering material</u>			
DN 2.5 - 25 / 1/10" - 1"		EPDM rings	
DN 40 - 100 / 1 1/2" - 4"		Rubber sleeves	
<u>Stud bolts</u>		Steel electrogalvanized, as option stainless steel 1.4301 or SS 304 - AISI	

Background
Wastewater
Water
Abrasive, corrosive and hot products
Non-contact measurement
Food, Beverage, Pharmaceutical
High Pressure and special connections
Signal converter and Remote
Remote
Calibration / Measuring Principle
Sizing / installation guides
Ordering guide

Dimensions and weights

Dimensions in mm and (inches)

PLEASE NOTE !

The **total dimension for the height** is obtained from **dimension b** (see table) **plus the height** of the terminal box or the signal converter, see drawings.

The **total weight** is made up of the weight of the signal converter (see table) **plus** the weight of the terminal box or signal converter, see below.

Meter size		Dimensions in mm and (inches)								Approx. weight in	
DN	mm	inches	a	b _{max}	d	e			kg	(lb)	
DN 2.5 - 15		1/10 - 1/2	65 (2.56)	123 (4.84)	51 (2.01)	44 (1.73)			1.6	(3.53)	
DN 25		1	58 (2.28)	116 (4.57)	34 (1.34)	102 (4.02)			1.6	(3.53)	
DN 40		1 1/2	83 (3.27)	131 (5.16)	42 (1.65)	117 (4.61)			2.4	(5.29)	
DN 50		2	103 (4.06)	149 (5.87)	51 (2.01)	135 (5.31)			2.9	(6.39)	
DN 80		3	153 (6.02)	181 (7.13)	67 (2.64)	167 (6.57)			6.4	(14.11)	
DN 100		4	203 (7.99)	206 (8.11)	79 (3.11)	192 (7.56)			8.8	(19.40)	

Meter size DN 2.5 - 15 and 1/10" - 1/2": Pipe flanges DN 15 / PN 40 or 1/2" / Class 150 lb (300 lb).

Necessary flange spacing

DN2.5 - 15, 1/10" - 1/2":

Dimension [a + 2 times gasket thickness]
(gasket between grounding rings and pipe flanges)

DN25 - 100, 1" - 4"

without grounding rings:
with grounding rings (option):

Dimension a incl. gaskets between primary head and pipe flanges
Dimension [a + 10 mm] or [a + 0.40"], incl. gaskets between grounding rings and pipe flanges

Terminal box

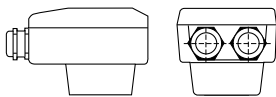

Weight approx. 0.5 kg (1.1 lb)

IFC 010 K and IFC 020 K signal converter

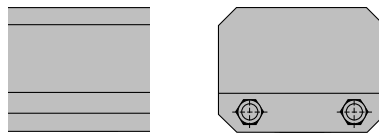

Weight approx. 1.6 kg (3.6 lb)

IFC 090 K signal converter

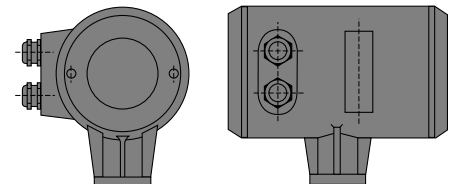

Weight approx. 2.3 kg (5.1 lb)

DN 2.5 - 15 / 1/10" - 1/2"

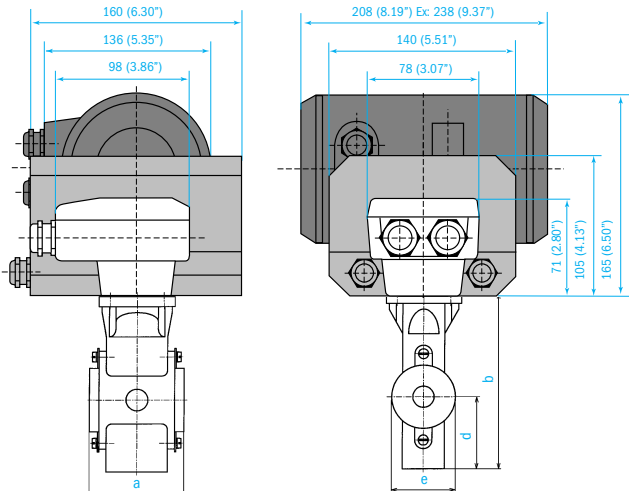

DN 25 - 100 / 1" - 4"

