

IFC 090 K, F Signal Converter for electromagnetic flowmeters

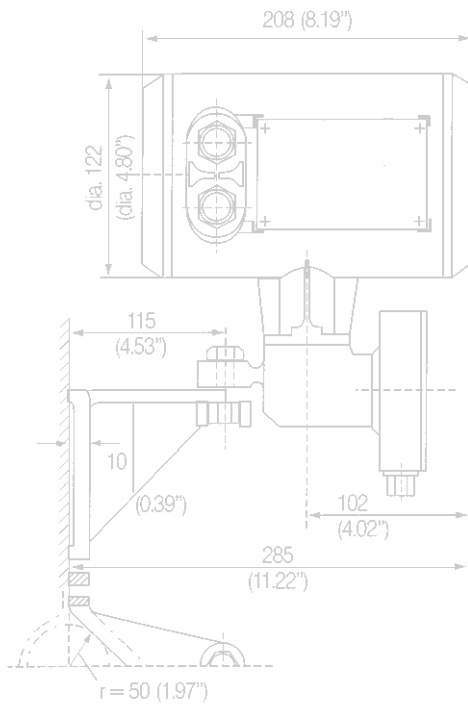
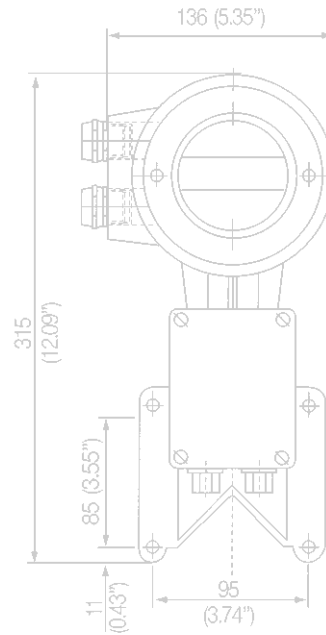

- Application limits have now been abolished!
- Measuring error guaranteed to be less than 0.3% of the measured value
- Excellent noise rejection, better by a factor of 10 as compared to the electromagnetic flowmeters normally in use

Variable area flowmeters

Vortex flowmeters

Flow controllers

Electromagnetic flowmeters

Ultrasonic flowmeters

Mass flowmeters

Level measuring instruments

Communications engineering

Engineering systems & solutions

IFC 090 K, F Signal Converter

for electromagnetic flowmeters

Highlights

KROHNE Ex-concept, flameproof enclosure, intrinsically safe outputs and inputs

Very good reproducibility and repeatability, also in the case of rapid changes in the rate of flow



Many different (scaled) outputs and inputs, options e.g. HART® and PROFIBUS

Extremely stable and accurate results with steady, subcritical or pulsating flows, also with up to 5% solids content

Large high-contrast LC display (option)



Measuring error guaranteed to be less than 0.3% of the measured value

The modular Krohne system will have the right electromagnetic flowmeter for your specific application – right from both the flowmetering and the economic viewpoint.

Technology to rave about

- μ P-controlled signal converter
- digital signal processing and sequence control
- internal IModCom interface (bus), allows modular retrofitting, e.g. with interfaces (RS 485/Profibus or HART)
- outputs and inputs can be operated in the active or passive mode
- current and pulse outputs galvanically isolated
- status and/or control input
- rapid response time, "real" time constant of 0.2 s
- all systems delivered ready to operate; install flowmeter in the pipeline, connect up, it's ready to go.
- low investment and follow-up costs, easy installation, low power consumption, high operational dependability, virtually maintenance-free

Calibrated on **EN 45 001** certified calibration rigs, accuracy of calibration better than 99.97% of the measured value



The modular Krohne system with the IFC 090 signal converter

Der **IFC 090 signal converter** is compatible with all Krohne primary heads:

Type code

K Compact systems: Primary head and signal converter form a single unit and are solidly connected.
F Separate systems: Primary head and signal converter are separate units and electrically connected by signal and field current cables.

IFM ... Electromagnetic flowmeter **IFS ...** primary head **IFC 090** Signal converter

Full data of the primary heads (IFS ...) are specified in the relevant Data Sheets:

ALTOFLUX .../AQUAFLUX .../ECOFLUX .../PROFILUX .../VARIFLUX ...

Compact systems with regedly mounted IFC 090 K		Separate systems Primary heads		System with IFC 090 F		Characterization of primary heads	
						Meter size	Flowtube / Connection
ECOFLUX	IFM 1080 K	ECOFLUX	IFS 1000 F	ECOFLUX	IFM 1080 F	DN 10-150 3/8"-6"	Teflon®-PFA liner, flangeless design ¹⁾
AQUAFLUX	080 K	AQUAFLUX	F	AQUAFLUX	080 F	DN 10-1600 3/8"-64"	Polypropylen and hard rubber liner, flanged design ¹⁾
ALTOFLUX	IFM 4080 K	ALTOFLUX	IFS 4000 F	ALTOFLUX	IFM 4080 F	DN 10-1600 3/8"-64"	e.g. Teflon®-PFA liner, flanged design
PROFILUX	IFM 5080 K	PROFILUX	IFS 5000 F	PROFILUX	IFM 5080 F	DN 2,5-100 1/10"-4"	fused aluminium oxide tube, flangeless design
VARIFLUX	IFM 6080 K	VARIFLUX	IFS 6000 F	VARIFLUX	IFM 6080 F	DN 10-80 3/8"-3"	Teflon®-PFA liner, food-grade and sterile connections
ALTOFLUX	IFM 3080 K	ALTOFLUX	IFS 3000 F	ALTOFLUX	IFM 3080 F	DN 10-300 3/8"-12"	for special applications, e.g. sanitary version, pressure ratings up to PN1500 or 20 000 psig, and field replaceable electrodes WE ¹⁾

¹⁾ not as hazardous-duty versions

Teflon® is a registered trademark of Du Pont.

Versions for hazardous-duty areas

Type of protection	Increased safety	Intrinsic safety
	IFC 090 K / Ex	IFC 090 K / i-EEEx
outputs / inputs	e	i
housing signal converter	d	d
terminal compartment of	e	e
outputs, inputs, power supply	(d , option for K)	(d , option for K)
power supply	e	e
electrodes signal cable	i	i
(only F version, separate)		
field power supply cable	e	e
(only F version, separate)		

e = increased safety

i = intrinsic safety

d = flameproof enclosure

K = compact units:

characteristic and approval No. see data sheets "Primary heads"

**F = separate units:
(field housing)**

characteristic EEx de [ib] IIC T6 approval No. KEMA Ex-97.D.2241

FM Factory Mutual:

Class III Div. 2 Groups A, B, C, D

Class III Div. 2 Groups F, G

Class III Div. 2 Groups

Background
Water
Wastewater
Abrasive, corrosive and hot products
Non-contact measurement
K < 0.05 µs/cm
Food, Beverage, Pharmaceutical
High Pressure and special connections
Signal converter Compact and Remote
Remote
Calibration / Measuring Principle
Sizing / Installation guides
Ordering guide

The standard

- outstanding accuracy
- full set of standard equipment
- current and pulse outputs (galvanically isolated)
- status and/or control output, easy to set for numerous tasks: as trip point, to indicate flow direction, error messages, external initiation of functions, etc.
- IMoCom bus can be used for numerous internal and external tasks
- simplified, standard Krohne operator control concept
- low power consum

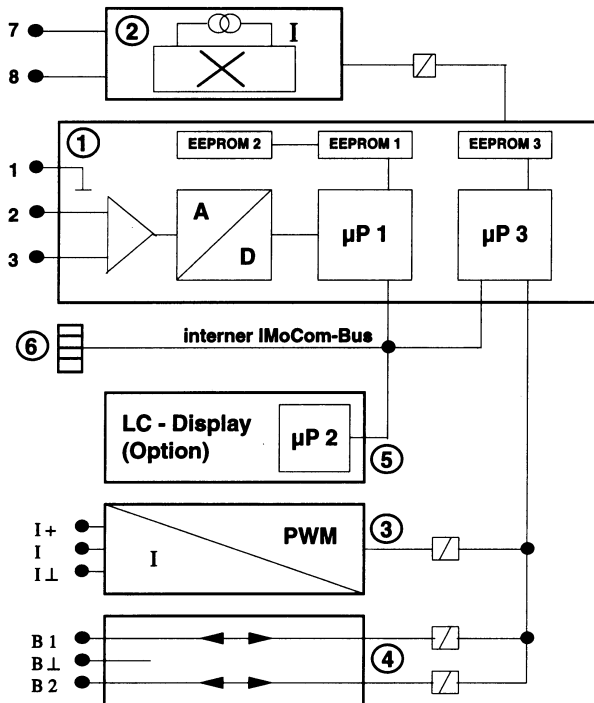

1 Input amplifier

- overdrive-proof signal processing, processes flow peaks up to 20 m/s (65 ft/s) and more rapidly and accurately
- digital signal processing and sequence control
- patented, high-resolution A/D converter, digitally controlled and monitored
- high signal-to-noise ratio through low-loss field power supply with high frequencies and currents

2 Field power supply

- The low-loss field power supply generates the pulsed, electronically controlled DC current for the magnetic coils of the primary head
- The high field current ensures a high signal level

3 Current output

- galvanically isolated from all other groups
- converts the digital output signal from the µP 3 microprocessor into a proportional current

4 Binary outputs and/or inputs

- galvanically isolated from other groups
- selectable input/output combinations
- pulse output (B1), passive FET optocouplers allow connection of electronic and electromechanical totalizers
- status output (B2) for limit value, error identification, or flow direction in forward/reverse flow mode (F/R) or measuring range identification in BA mode
- both outputs can also be used as control inputs

5 Display/operator control unit (option, D Version)

- large-size illuminated LC display
- 3 keys for operator control of the signal converter
- connection to the internal IMoCom bus
- unit can be retrofitted to basic devices (B Version)

6 IMoCom bus plug connector

- for connection of external control and test devices such as:
 - HHT handheld terminal (option), display/operator control unit for operation of basic versions
 - adapter and CONFIG software for operation via MS-DOS PC

Selection of meter size

The optimum flow velocity should be 2 – 3m/s or 6 – 9ft/s, for products with solids contents between 3 and 5m/s or 9 and 15ft/s. The exact flow velocity can be determined from the columns in the tables for $v = 12\text{ m/s}$ or $v = 40\text{ ft/s}$ as shown in the following examples.

Example for m³/h

- Meter size: DN80
- Desired measuring range: 55 m³/h

From the table obtain for $v = 12\text{ m/s}$ the flow rate of 217.1 m³/h at DN80.

$$v = \frac{55\text{ m}^3/\text{h}}{217.1\text{ m}^3/\text{h}} \times 12\text{ m/s}$$

$$v = 3.04\text{ m/s}$$

Example for US Gal/min

- Meter size: 3"
- Desired measuring range: 200 USGal/min

From the table obtain for $v = 40\text{ ft/s}$ the flow rate of 955.9 USGal/min at 3" meter size.

$$v = \frac{200\text{ USGal}/\text{min}}{955.9\text{ USGal}/\text{min}} \times 40\text{ ft/s}$$

$$v = 8.37\text{ ft/s}$$

Error limits

similar to EN 29104

Display, digital values, pulse output

F maximum error in % of measured value (not typical values)

v Flow velocity in m/s and ft/s

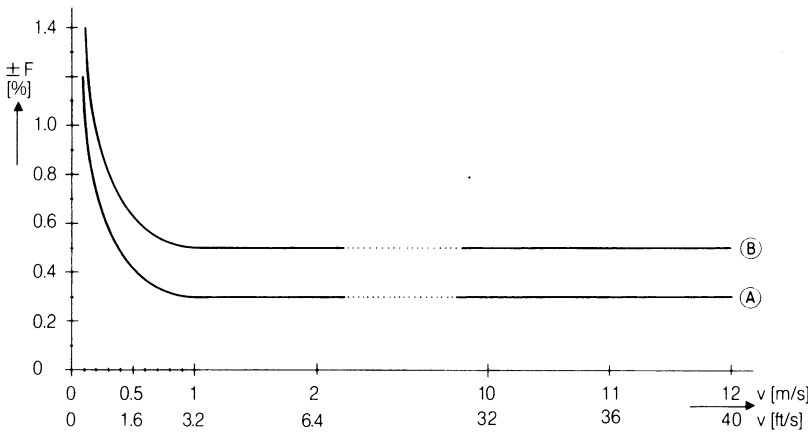

Reference conditions similar to EN 29104

Product	water at 10 – 30 °C / 50 – 86 °F
Electrical conductivity	> 300 µS/cm
Power supply (rated voltage)	U _N (± 2 %)
Ambient temperature	20 – 22 °C / 68 – 71.6 °F
Warm-up time	60 min
Inlet/outlet runs	10 x DN / 2 x DN (DN = meter size)
Primary head	properly grounded and centered
	● Calibrated on EN 45001 certified calibration rigs by direct comparison of volumes

Type/Meter size	Maximum error in % of measured value (MV)	Curve
DN mm	$v \geq 1\text{ m/s} / \geq 3\text{ ft/s}$	
DN 2.5 – 6*	$v < 1\text{ m/s} / < 3\text{ ft/s}$	
(IFS 1000 F all meter size)	$\leq \pm 0.5\%$ of MV	B
	$\leq \pm (0.4\% \text{ MV} + 1\text{ mm/s})$	
	$\leq \pm (0.4\% \text{ MV} + 0.04\text{ inch/s})$	
$\geq \text{DN } 10$	$\leq \pm 0.3\%$ of MV	A
	$\leq \pm (0.2\% \text{ MV} + 1\text{ mm/s})$	
	$\leq \pm (0.2\% \text{ MV} + 0.04\text{ inch/s})$	

Current output same error limits as above, additionally $\pm 10\text{ }\mu\text{A}$

Reproducibility and repeatability 0.1% of MV, minimum 1mm/s / 0.04inch/s at constant flow

External influences typical values maximum values

Ambient temperature	typical values	maximum values	
Pulse output	0.003 % of MV (1)	0.01 % of MV (1)	} at 1 K / 1.8 °F variation
Current output	0.01 % of MV (1)	0.025 % of MV (1)	
Power supply	< 0.02 % of MV	0.05 % of MV	at 10% variation
Load	< 0.01 % of MV	0.02 % of MV	at max. permissible load, see pages 6 and 7

(1) All Krohne signal converters undergo burn-in tests, duration minimum 20 hours at varying ambient temperatures - 20 to + 60 °C / - 4 to + 140 °F. The tests are controlled by computers.

Technical data

Versions		Basic version = B without local display and control elements		Display version = D (option) with local display and control elements	
		K = compact	F = separate	K = compact	F = separate
Standard (A)		IFC 090 K/B	IFC 090 F/B	IFC 090 K/D	IFC 090 F/D
Ex-nA	Ex version (nA) with approval for zone 2	IFC 090 K/B/Ex-nA	IFC 090 F/B/Ex-nA	IFC 090 K/D/Ex-nA	IFC 090 F/D/Ex-nA
Ex-e	Ex version (e) increased safety	on request	on request	IFC 090 K/Ex	IFC 090 F/Ex
Ex-i	Ex version (i) intrinsic safety	on request	on request	IFC 090 K/i-EEx	IFC 090 F/i-EEx
FM	Factory Mutual Ex-Div. 2	IFC 090 K/B - Ex-Div. 2	IFC 090 F/B - Ex-Div. 2	IFC 090 K/D - Ex-Div. 2	IFC 090 F/D - Ex-Div. 2
Add-on equipment (option)		CONFIG software and adapter for operator control via MS-DOS PC, connection to internal IMoCom interface (equipment bus)			

PLEASE NOTE

Combinations of outputs, inputs and interfaces, see Table Page 8

Current output

Function	- all operating data settable - galvanically isolated from current output and all input circuits - for active or passive mode
Current: fixed ranges variable ranges	0 - 20 mA and 4 - 20 mA (Ex-i: only 4 - 20 mA for Q = 0% $I_{0\%} = 0 - 16\text{ mA}$ for Q = 100% $I_{100\%} = 4 - 20\text{ mA}$ for Q > 100% $I_{\text{max}} = 22\text{ mA}$ } adjustable in 1 mA increments
Electrical data	see "Connection diagrams" on Page 9
Error identification	0 / 22 mA and variable
Forward/reverse flow measurement	direction identified via status output

Pulse output

Function	- all operating data settable - galvanically isolated from all input and output circuits - digital pulse division, interpulse period non-uniform, therefore if frequency and cycle meters connected allow for minimum counting interval: $\text{gate time, totalizer} \geq \frac{1000}{P_{100\%} [\text{Hz}]}$
Active mode	connection: electronic totalizers
Passive mode	connection: electronic or electromechanical totalizers
Electrical data	see "Connection diagrams" on Page 9
Pulse width	automatic: pulse duty cycle 1:1, max 1000 pulses/s = 1 kHz (Ex-i: 10 kHz) variable: $10\text{ ms} - 2\text{ s}$ $P_{100\%} [\text{pulses/s}] = f_{\text{max}} [\text{Hz}] = \frac{1}{2 \times \text{pulse width}}$
Forward/reverse flow measurement	flow direction identified via status output

Status output (passive)

Function	settable as measuring range identification for BA mode, indicator for flow direction, errors or trip point
Electrical data	see "Connection diagrams" on Page 9

Control input (passive)

Function	- settable for range change, totalizer reset, error reset, set outputs to min. values or hold actual output values - initiate function by "low" or "high" control signals
Control signals	U_{max} : 24 V AC 32 V DC (any polarity) low: $\leq 1,4\text{ V}$ $\leq 2\text{ V}$ high: $\geq 3\text{ V}$ $\geq 4\text{ V}$

Time constant

0.2 - 99.9 s, adjustable in increments of 0.1 second

Low-flow cutoff

Cutoff "on" value: 1 - 19%
Cutoff "off" value: 2 - 20% } of $Q_{100\%}$, adjustable in 1% increments

Local display (D version)		3-field LCD			
Display function		actual flowrate, forward, reverse and sum totalizers (7-digit), or 25-character bar graph with percentage indication and status messages			
Units:	Actual flowrate	m ³ /h, liters., US gallons/min or user-defined unit, e. g. liters/day			
Totalizer		m ³ , liters, US gallons or user-defined unit, e. g. hecto-liters or US gallons/day (adjustable count duration up to overflow)			
Language of plain texts		English, German, French, others on request			
Display:	Top field	8-character, 7-segment numeral and sign display, and symbols for key acknowledgement			
	Middle field	10-character, 14-segment text display			
	Bottom field	4 markers to identify display in measuring mode			
Power supply		1. AC Version	2. AC Version	AC/DC Version	
IFC 090		Standard	Option	Option	
	1. Rated voltage	230 / 240V	200V	24V AC	24V DC
	Tolerance band	2w - 260V	170 - 220V	20 - 27V AC	18 - 32V DC
	2. Rated voltage	115 / 120V	100V	-	-
	Tolerance band	100 - 130V	85 - 110V	-	-
IFC 090 Ex - i:		230/240V	-	24V AC	24V DC
(not Ex - i3/Ex - i5)	Tolerance band	200 - 260V		20 - 24V AC	18 - 32V DC
Frequency		48 - 63Hz		48 - 63Hz -	
Power consumption (incl. primary head)		approx. 10VA		approx. 10VA	approx. 8W
When connected to functional extra-low voltage, 24V, safety separation (PELV) is essential (to VDE 0100/VDE 0106 and IEC 364/IEC 536 or equivalent national standard).					
Housing					
Material		die-cast aluminium with polyurethane finish			
Ambient temperature		- 25 to + 60 °C (- 13 to + 140 °F)			
Protection category (IEC 529/EN 60529)		IP67, equivalent to NEMA 6			
Cable entries		PG 13.5 or 1/2" NPT			

Dimensions and weights

dimensions in mm and (inch)

IFC 090 F Signal converter

Weight approx. 4.2 kg/9.3 lbs

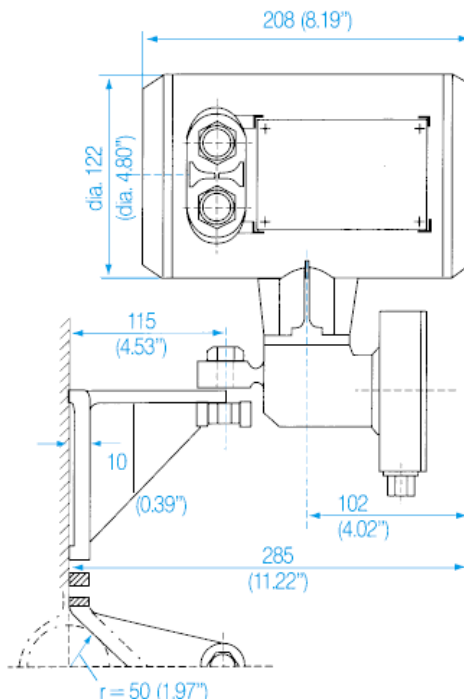
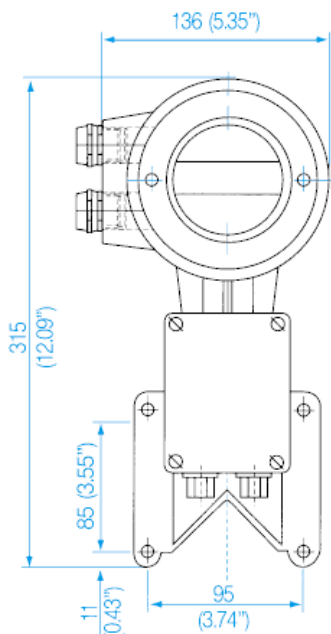

ZD Intermediate connection box

Weight approx. 0.5 kg/1.1 lbs

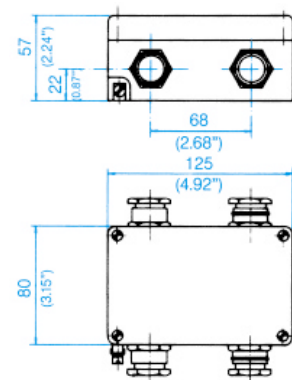

Background
Water Wastewater
Abrasive, corrosive and hot products
Non-contact measurement K > 0.05 µS/cm
Food, Beverage, Pharmaceutical
High Pressure and special connections
Signal converter Compact and Remote
Remote
Calibration / Measuring Principle
Sizing / Installation guides
Ordering guide

Output/input combinations

Versions		I Current Output	P Pulse output or S Status output or C Control input	S Status output or C Control input	HART® PROFI- BUS	Terminals	Connection diagrams (see Page 9)	
A	standard	active or passive	active or passive	active or passive	option	-		1, 2, 4, 5, 6, 7, 8, 9, 10
B		passive	-	-	HART® or PROFIBUS, selectable	-		2
D			passive	-	-	yes		5, 6, 8, 10
Ex-nA	operation in zone 2	active or passive	active or passive	active or passive	option	-		1, 2, 4, 5, 6, 7, 8, 9, 10
Ex-e	increased safety	active	passive	passive	option	-		1, 5, 6, 8, 10
Ex-i1	intrinsic safety	passive	passive	-	yes	-		2, 5, 6, 8, 10
Ex-i2	intrinsic safety	passive	-	-	HART® or PROFIBUS, selectable	-		2
Ex-i3	intrinsic safety, with internal power source	active	-	-	yes	-		1
Ex-i4	intrinsic safety	-	passive	-	-	yes		5, 6, 8, 10
Ex-i5	intrinsic safety, with internal power source	-	active	-	-	-		4, 7, 9
Ex-i6	intrinsic safety	-	passive	passive	-	-		5, 6, 8, 10
Ex- Div. 2	FM	active or passive	active or passive	active or passive	option	-		1, 2, 4, 5, 6, 7, 8, 9, 10

Connection diagrams of outputs and inputs

- I Current output (and optionally HART®)
- B1 Pulse output (P) or status output (S) or control input (C)
- B2 Status output (S) or control input (C)
- D PROFIBUS

- Totalizer electronic
- EMC elektromechanical
- EC elektronik
- Milliammeter
- 0 or 4 - 20 mA

Active mode

For operation (selection) of the outputs and inputs the power supply is supplied from the current output (versions **A**, **Ex-nA**, **Ex-Div. 2** and **Ex-e**) or from the internal power source (versions **Ex-i3** and **Ex-i5**).

Passive mode

External power source required for operation (selection) of the outputs and inputs.

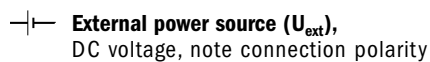
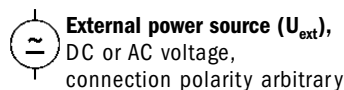
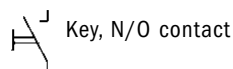

If to be connected to a functional extra-low voltage source (24 V), protective separation in conformity with VDE 0100, Part 410, or equivalent national standard, must be ensured.

Electrical connection in conformity with VDE 0100 "Regulations governing heavy-current installations with mains voltages up to 1000 V" or equivalent national standard.

① **Current output I_{active}**

Version: **A/D/ Ex-nA/ Ex-e/ Ex-Div. 2**

$I = 0/4 - 20\text{ mA}$
 $R_L < 500\ \Omega$

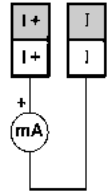

Version: **Ex-i3**

$I = 4 - 20\text{ mA}$
 $R_L < 350\ \Omega$

② **Current output $I_{passive}$**

Version: **A/B/ Ex-nA/ Ex-Div. 2**

U_{ext}	15 - 20V DC	20 - 32V DC
R_L	0 - 500 Ω	250 - 750 Ω
$I =$	0/4 - 20mA	

Version: **Ex-i1/ Ex-i2**

$U_{ext} = 8.1 - 30\text{V DC}$
 $R_L = \frac{U_{ext} - 8\text{V}}{22\text{mA}}$
 $I = 4 - 20\text{mA}$

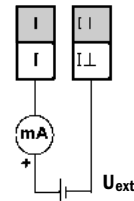

③ **24 V DC or AC for power supply, outputs and inputs B1 and B2**

Version: **A/ Ex-nA/ Ex-e/ Ex-Div. 2**

$U_{ext} = 18 - 30\text{V DC}$
 $U_{ext} = 20 - 26\text{V AC}$
 $I_{max} \leq 150\text{mA DC/AC}$
 B1 e.g. totalizer, indication (load) or control elements
 B2 e.g. indication (load) or control elements

Connection of outputs and inputs see diagrams 4, 7 and 9

outputs and inputs | power supply

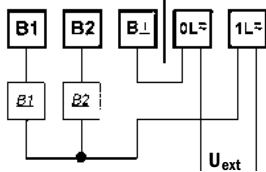

④ **Current output P_{active} for EC**

Version: **A/ Ex-nA/ Ex-Div. 2**

$U_{int} \leq 15\text{V DC}$ from current output I
 $I_{max} \leq 03\text{ mA}$ operation with current output I
 $I_{max} \leq 23\text{ mA}$ operation without current output I

Version: **Ex-i5**

$U_{int} = 20\text{V DC}$
 $R_i = 260\ \Omega$
 $U_L = \frac{20\text{V} \times R_L}{260\ \Omega + R_L}$

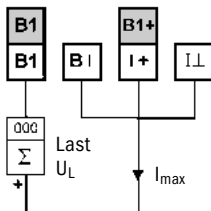

⑤ **Pulse output $P_{passive}$ for EC or EMC**

Version: **A/ Ex-nA/ Ex-e/ Ex-Div. 2**

$U_{ext} \leq 30\text{V DC} / \leq 24\text{V AC}$
 $I_{max} \leq 150\text{ mA}$

Version: **Ex-i1/ Ex-i4/ Ex-i6**

$U_{ext} \leq 30\text{V DC}$
 $I_{max} \leq 110\text{ mA}$

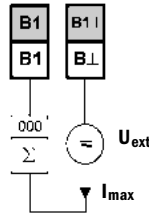

⑥ **Pulse output $P_{passive}$ for active EC**

Version: **A/D/ Ex-nA/ Ex-e/ Ex-Div. 2**

$U_{ext} \leq 30\text{V DC} / \leq 24\text{V AC}$
 $I_{max} \leq 150\text{ mA}$

Version: **Ex-i1/ Ex-i4/ Ex-i6**

$U_{ext} \leq 30\text{V DC}$
 $I_{max} \leq 110\text{ mA}$

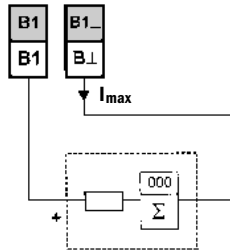

⑦ **Status output S_{active} (connection to B1 and/or B2)**

Version: **A/ Ex-nA/ Ex-Div. 2**

$U_{int} \leq 15\text{V DC}$ from current output I
 $I_{max} \leq 3\text{ mA}$ operation with current output I
 $I_{max} \leq 23\text{ mA}$ operation without current output I

Version: **Ex-i5**

$U_{int} = 20\text{V DC}$
 $R_i = 260\ \Omega$
 $U_L = \frac{20\text{V} \times R_L}{260\ \Omega + R_L}$

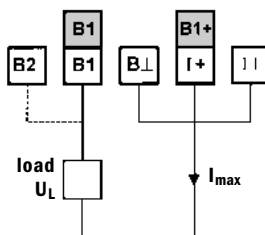

⑧ **Status output $S_{passive}$ (connection to B1 and/or B2)**

Version: **A/D/ Ex-nA/ Ex-e/ Ex-Div. 2**

$U_{ext} \leq 30\text{V DC} / \leq 24\text{V AC}$
 $I_{max} \leq 150\text{ mA}$

Version: **Ex-i1/ Ex-i4/ Ex-i6**

$U_{ext} \leq 30\text{V DC}$
 $I_{max} \leq 110\text{ mA}$

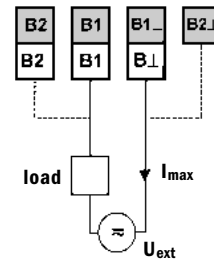

⑨ **Control input C_{active} (connection to B1 and/or B2)**

Version: **A/ Ex-nA/ Ex-Div. 2**

$U_{int} \leq 15\text{V DC}$ from current output I

Version: **Ex-i5**

$U_{int} = 20\text{V DC}$

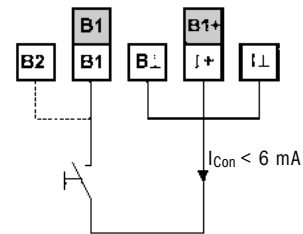

$I_{con} =$ max. contact load

⑩ **Control input $C_{passive}$ (connection to B1 and/or B2)**

Version: **A/D/ Ex-nA/ Ex-e/ Ex-Div. 2**

$U_{ext} \leq 30\text{V DC} / \leq 24\text{V AC}$

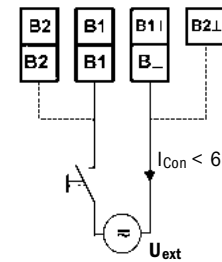

$I_{con} =$ max. contact load

Background

Water Wastewater

Abrasive, corrosive and hot products

Non-contact measurement $K < 0.05\ \mu\text{s/cm}$

Food, Beverage, Pharmaceutical

High Pressure and special connections

Signal converter Compact and Remote

Remote

Calibration / Measuring Principle

Sizing / Installation guides

Ordering guide

IFC 090 F Electrical connection

Signal cable A (type DS) for transmission the signals from the primary head to the signal converter

The signals transmitted from the primary head electrode circuit to the signal converter are in the mV range and are sensitive to magnetic and electrostatic pick-up from adjacent heavy-current cables, electric drives, etc.

To ensure faultless system operation even under unfavourable electrical operating conditions, Krohne recommends the use of signal cables with foil and additional magnetic shields (mu metal) that have been specially developed for this application.

Advantages

- easy and time-saving connection method, as the shields are connected via stranded drain wires.
- suitable for underwater and underground installation
- insulating material flame-retardant to IEC 332.1/VDE 0472
- low halogen content, unplasticized
- remains flexible at low temperatures
- also available with blue sheath for intrinsically safe electrode circuit

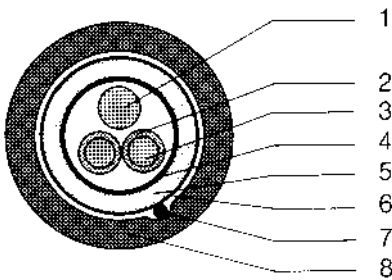

- 1 Stranded drain wire, 1st shield, 1.5 mm² or AWG 14
- 2 Insulation
- 3 Stranded wire 0.5 mm² or AWG 20
- 4 Special foil, 1st shield
- 5 Insulation
- 6 Mu metal foil, 2nd shield
- 7 Stranded drain wire, 2nd shield, 0.5 mm² or AWG 20
- 8 Outer sheath

Field power supply cable C

Length		Type of cable, single shielding
0 - 150m	0 - 500ft	2 x 0.75 mm ² Cu / 2 x 18AWG
150 - 300m	500 - 1000ft	2 x 1.50 mm ² Cu / 2 x 14AWG
300 - 600m	1000 - 1900ft	2 x 2.50 mm ² Cu / 2 x 12AWG

Distance between primary head and signal converter

- A** Signal cable A (type DS), with double shielding, max length (L) is dependent on electrical conductivity (κ) of product, see Diagram
- C** Field power supply cable, 2 x 0.75 mm² Cu / 2 x AWG 18, single shielding, not supplied
- D** High-temperature silicone cable, 3 x 1.5 mm² Cu or 3 x 14 AWG, with single shielding, color: red/brown, length max. 5 m or 16 ft
- E** High-temperature silicone cable, 2 x 1.5 mm² Cu or 2 x 14 AWG, color: red/brown, length max. 5 m or 16 ft
- L** Max. length of cables
- κ Electrical conductivity of the product
- ZD** Intermediate connection box, required in conjunction with cables D + E for primary head IFS ALTOFLUX 4000 F, PROFIFLUX IFS 5000 F and VARIFLUX IFS 6000 F where product temperatures exceed 150 °C or 302 °F

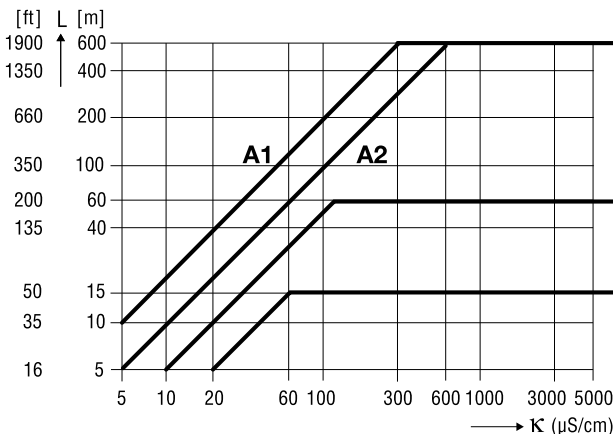

Primary head	Meter size		Signal cable
	DN mm	inch	
ECOFLUX IFS 1000 F	10 - 15	3/8 - 1/2	A4
	25 - 150	1 - 6	A3
AQUAFLUX F	10 - 1600	3/8 - 64	A1
ALTOFLUX IFS 4000 F	10 - 150	3/8 - 6	A2
	200 - 1600	8 - 64	A1
PROFIFLUX IFS 5000 F	2.5 - 15	1/10 - 1/2	A4
	25 - 100	1 - 4	A2
VARIFLUX IFS 6000 F	2.5 - 15	1/10 - 1/2	A4
	25 - 80	1 - 3	A2
ALTOFLUX M 900	10 - 300	3/8 - 12	A1

Connection diagrams

- The figures in brackets refer to the stranded drain wires for the shields, see sectional drawing of signal cable A on page 10.
- Electrical connection in conformity with VDE 0100 "Regulations governing the installation of heavy-current systems with mains voltages up to 100 V" or equivalent national standard.
- Supply power 24 V AC/DC: functional extra-low voltage with protective separation to VDE 0100, Part 410 or equivalent national standard.

FE functional ground

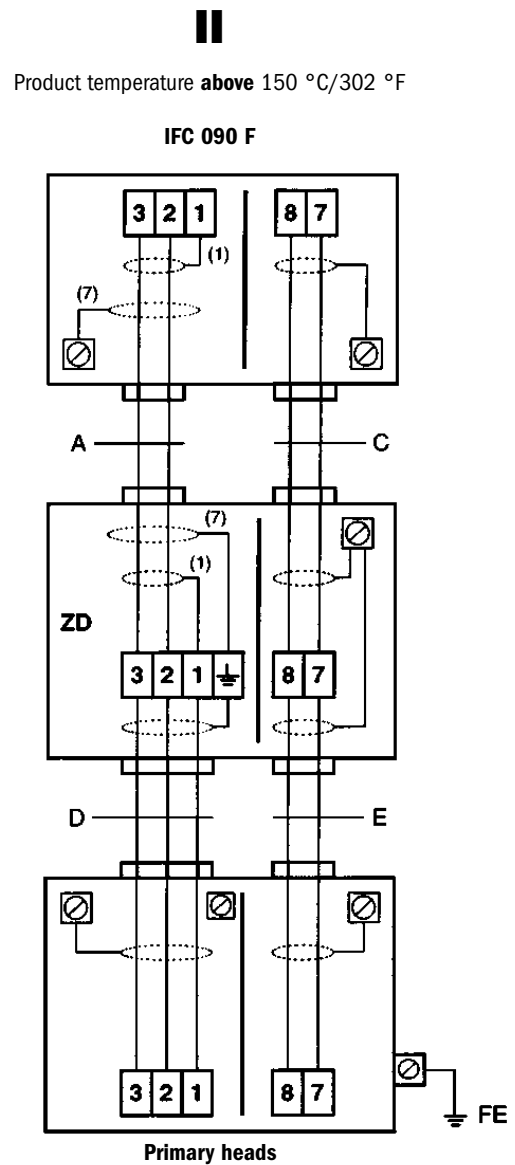
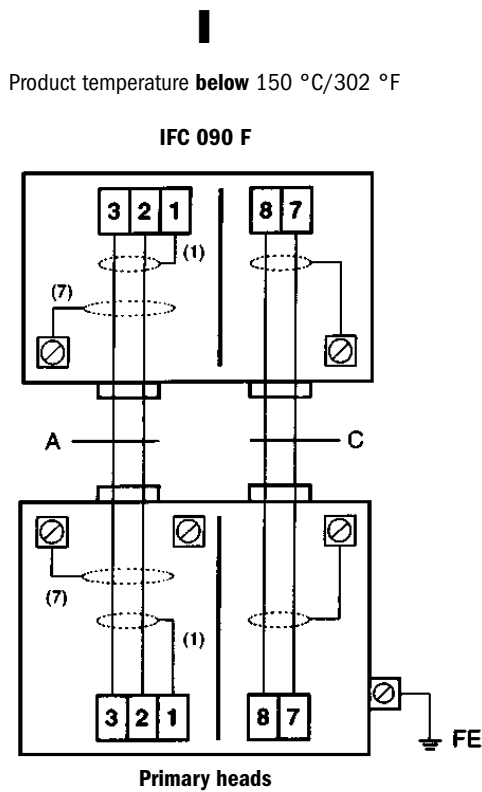

IFC 090 K and IFC 090 F connection to power supply

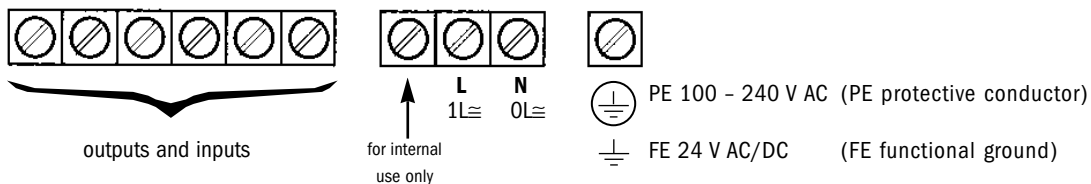

Background
Water Wastewater
Abrasive, corrosive and hot products
Non-contact measurement $K < 0.05 \mu\text{s}/\text{cm}$
Food, Beverage, Pharmaceutical
High Pressure and special connections
Signal converter Compact and Remote
Remote
Calibration / Measuring Principle
Sizing / Installation guides
Ordering guide